

# Infusion & Pump Stands

Mobile Infusion Stands	222
Clamping Infusion Stands	227
Wall Mounted Infusion Holders	227
Mobile Pump Stands	228



# Mobile Infusion Stands - Polyurethane, Easy Clean

## Features

- Meets appendix A (Stability Requirements) of BS 3619:1976 Mobile Infusion Stands
- Five leg base with low centre of gravity to assist stability
- 25mm diameter 304 grade stainless steel upright
- Polyurethane overmoulded base with smooth edges & contours provides...
  - Water-resistant finish, allowing for easy & effective cleaning (including steam cleaning)
  - Shield for the castors
  - Impact protection to patients & staff, reducing the risk of skin abrasions & bruising
  - Protection to the fabric of the building
- Coloured indicator caps provide department identification & segregation, reducing the risk of cross contamination
- Height adjustable upright using a handwheel (1260 - 2100mm)
- Available with two or four pigtail hooks
- Maximum recommended load...
  - Hooks - 4kg per stand
  - Fixed Upright - 4kg per stand
- Optional handle keeps feet clear of the base, assists manoeuvrability & improves patient safety
- 50mm polypropylene / thermoplastic rubber twin-wheel non-marking castors (1 x anti-static)

## Dimensions (w x d x h)

- Overall - 620 x 620 x 1260 - 2100mm
- Vertical Clamping Area
  - IS/P/2H & IS/P/4H - 970mm
  - IS/P/2H/H & IS/P/4H/H - 840mm

## Standard Colours

- Base - Grey
- Upright & Handle - Stainless Steel
- Coloured Indicator Cap - Spearmint

## Options

- Coloured Indicator Cap - Blue / Green / Red / Yellow



4 hook pole supplied with models with '4H' product code suffix



IS/P/2H/SP



IS/P/4H/H/YE  
(Pump not included)

Spearmint	Blue	Green	Red	Yellow	Description	Weight
IS/P/2H/SP	IS/P/2H/BL	IS/P/2H/GR	IS/P/2H/RD	IS/P/2H/YE	Two Hook	7.8kg
IS/P/4H/SP	IS/P/4H/BL	IS/P/4H/GR	IS/P/4H/RD	IS/P/4H/YE	Four Hook	7.9kg
IS/P/2H/H/SP	IS/P/2H/H/BL	IS/P/2H/H/GR	IS/P/2H/H/RD	IS/P/2H/H/YE	Two Hook, Handle	8.2kg
IS/P/4H/H/SP	IS/P/4H/H/BL	IS/P/4H/H/GR	IS/P/4H/H/RD	IS/P/4H/H/YE	Four Hook, Handle	8.3kg

## Mobile Infusion Stands - Polyurethane, Easy Clean

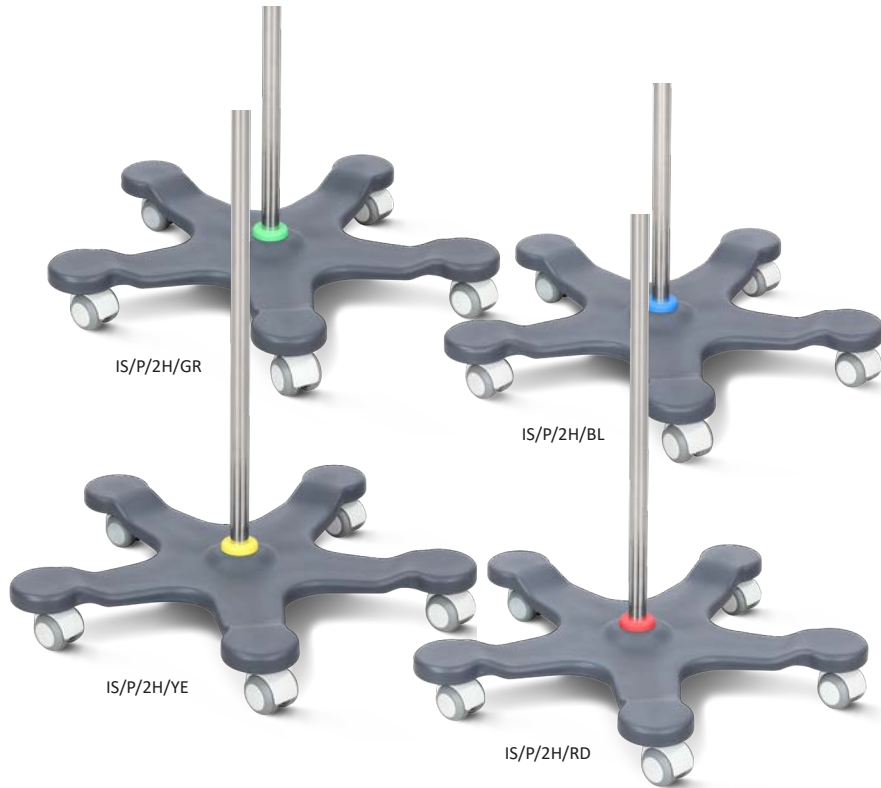

eClean™

## Mobile Infusion Stands - Stainless Steel

### Features

- Meets appendix A (Stability Requirements) of BS 3619:1976 Mobile Infusion Stands
- Seamless welded 304 grade stainless steel construction
- Height adjustable upright using a handwheel (1270 - 2000mm)
- Available with two or four pigtail hooks
- 9kg plastic coated weighted base available for additional stability
- Maximum recommended load...
  - Hooks - 4kg per stand
  - Fixed Upright
    - Non-Weighted Base - 2kg per stand
    - Weighted Base - 4kg per stand
- 50mm polypropylene / thermoplastic rubber twin wheel castors (1 x anti-static)

### Dimensions (w x d x h)

- 650 x 650 x 1270 - 2000mm

### Standard Colours

- Base / Upright - Stainless Steel
- Weighted Base - Grey

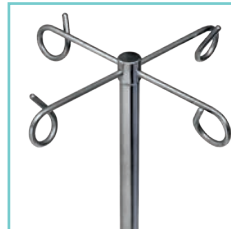

4 hook pole supplied with models with '4H' product code suffix

Item	Description	Weight
<b>Non Weighted Base</b>		
DPWS/1	Two Hook	3.8kg
DPWS/1/4H	Four Hook	3.9kg
<b>Weighted Base</b>		
DPWS/1/W9	Two Hook, Weighted Base	12.8kg
DPWS/1/W9/4H	Four Hook, Weighted Base	12.9kg



DPWS/1/W9/4H



DPWS/1



# Mobile Infusion Stands - Mild Steel

## Features

- Meets appendix A (Stability Requirements) of BS 3619:1976 Mobile Infusion Stands
- Welded mild steel construction
- Height adjustable upright using a handwheel (1270 - 2000mm)
- Available with two or four pigtail hooks
- 9kg plastic coated weighted base available for additional stability
- Maximum recommended load...
  - Hooks - 4kg per stand
  - Fixed Upright
    - Non-Weighted Base - 2kg per stand
    - Weighted Base - 4kg per stand
- 50mm polypropylene / thermoplastic rubber twin wheel castors (1 x anti-static)

## Dimensions (w x d x h)

- 650 x 650 x 1270 - 2000mm

## Standard Colours

- Base / Upright - Paint - White
- Weighted Base - Grey

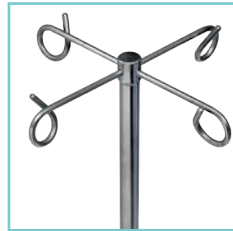

4 hook pole supplied with models with '4H' product code suffix

Item	Description	Weight
<b>Non Weighted Base</b>		
DPWM/1	Two Hook	3.8kg
DPWM/1/4H	Four Hook	3.9kg
<b>Weighted Base</b>		
DPWM/1/W9	Two Hook, Weighted Base	12.8kg
DPWM/1/W9/4H	Four Hook, Weighted Base	12.9kg



DPWM/1



DPWM/1/W9/4H



## Mobile Infusion Stands - Knockdown

### Features

- Meets appendix A (Stability Requirements) of BS 3619:1976 Mobile Infusion Stands
- 304 grade stainless steel legs & upright with a plastic centre boss
- Unique design allows for assembly using an Allen key to locate & hold the legs & upright in position
- Supplied boxed for self-assembly
- Height adjustable upright using a handwheel (1270 - 2000mm)
- Available with two or four pigtail hooks
- Maximum recommended load on hooks 4kg (attachment of blood warmers, pumps & syringe drivers is not recommended)
- 50mm polypropylene twin-wheel castors (1 x anti-static)

### Dimensions (w x d x h)

- 650 x 650 x 1270 - 2000mm

### Standard Colours

- Legs / Upright - Stainless Steel
- Centre Boss - Grey



Item	Description	Weight
DPKS/1	Mobile Infusion Stand - Knockdown, Two Hook	3.8kg
DPKS/1/4H	Mobile Infusion Stand - Knockdown, Four Hook	3.9kg



## Infusion Poles - Replacement

### Features

- Two & four pigtail hook stainless steel infusion poles
- Compatible with our drip stands (19mm diameter upright)
- Pole length 1200mm

### Standard Colours

- Stainless Steel

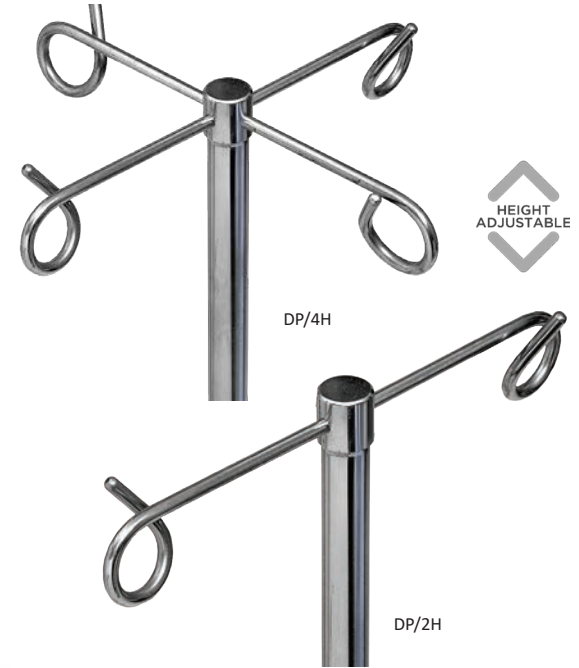

Item	Description	Weight
DP/2H	Two Hook Infusion Pole	0.6kg
DP/4H	Four Hook Infusion Pole	0.8kg

## Clamping Infusion Stands - Trolley

### Features

- Clamp secures to 25mm vertical round tube (designed to fit our range of dressing trolleys)
- When fitting to other trolleys, we strongly recommend that a risk assessment is carried out to assess stability
- When fitted protrudes 45mm
- Supplied with a two pigtail hook infusion pole
- Maximum load on hooks 2kg

### Dimensions (w x d x h)

- 55 x 220 x 1200mm



## Wall Mounted Infusion Holders

### Features

- Wall mounted infusion bag holder
- Available with one/two U shaped hooks
- 25mm diameter "D" shaped tube to accept pumps (max load 10kg)
- Maximum load per hook 2kg
- Fixings not included

### Dimensions (w x d x h)

- IV001 - 344 x 75 x 500mm
- IV002 - 344 x 75 x 570mm



IV002

IV001



Item	Description	Weight
DP/C	Clamping Infusion Stands - Trolley	1.8kg

Item	Description	Weight
IV001	One Hook, Wall Mounted Infusion Holder	1.2kg
IV002	Two Hook, Wall Mounted Infusion Holder	1.6kg



## Mobile Pump Stands - Polyurethane, Easy Clean

### Features

- Range of stands designed specifically to hold blood warmers, pumps & syringe drivers
- Five leg base with low centre of gravity to assist stability
- 32mm diameter 304 grade stainless steel upright & 25mm diameter pump support bows
- Polyurethane overmoulded base with smooth edges & contours provides...
  - Water-resistant finish, allowing for easy & effective cleaning (including steam cleaning)
  - Shield for the castors
  - Impact protection to patients & staff, reducing the risk of skin abrasions & bruising
  - Protection to the fabric of the building
- Height adjustable upright using a handwheel (1300 - 2000mm)
- Four U shaped hooks
- Maximum recommended load...
  - Hooks - 12kg per stand
  - Fixed Upright/s - 22kg per stand
- 75mm polypropylene / thermoplastic rubber twin-wheel castors (1 x anti-static)

### Dimensions (w x d x h)

- Overall - 620 x 620 x 1300 - 2000mm
- Vertical Clamping Area
  - PS/P/SC/4H - 975mm
  - PS/P/HC/4H - 771mm (upright) 2 x 646mm (support bows)

### Standard Colours

- Base - Grey
- Upright & Support Bows - Stainless Steel

### Vertical Clamping Area

- PS/P/SC/4H - 975mm
- PS/P/HC/4H - 771mm (upright) 2 x 646mm (support bows)



Smooth edges & contours, allows easy & effective cleaning



Item	Description	Weight
PS/P/SC/4H	Mobile Pump Stand - Polyurethane, Easy Clean, Standard Capacity, Four Hook	11.0kg
PS/P/HC/4H	Mobile Pump Stand - Polyurethane, Easy Clean, High Capacity, Four Hook	13.0kg

# eClean™



Four U shaped hooks



Height adjustable upright using a heavy duty handwheel

CE



PS/P/HC/4H  
(Pumps not included)

## Mobile Pump Stands - Mild Steel, Four Leg

### Features

- Range of stands designed specifically to hold blood warmers, pumps & syringe drivers
- Fully welded four leg base
- 32mm diameter 304 grade stainless steel upright & 25mm diameter pump support bows
- Height adjustable upright using a handwheel (1270 - 2000mm)
- Four U-shaped hooks
- Maximum recommended load...
  - Hooks - 12kg per stand
  - Fixed Upright/s - 22kg per stand
- 75mm polypropylene / thermoplastic rubber twin-wheel castors (1 x anti-static)

### Dimensions (w x d x h)

- Overall - 560 x 621 x 1270 - 2000mm
- Vertical Clamping Area
  - PS/M/SC/4H - 975mm
  - PS/M/HC/4H - 771mm (upright) 2 x 646mm (support bows)

### Standard Colours

- Base - Grey
- Upright & Support Bows - Stainless Steel



Item	Description	Weight
PS/M/SC/4H	Mobile Pump Stand - Mild Steel, Four Leg, Standard Capacity, Four Hook	14.7kg
PS/M/HC/4H	Mobile Pump Stand - Mild Steel, Four Leg, High Capacity, Four Hook	16.7kg



Four U shaped hooks



Height adjustable upright using a heavy duty handwheel



PS/M/HC/4H  
(Pumps not included)