



Mobile Computer Carts



Adding value to healthcare

Mobile Computer Carts

Phlebotomy



Diagnostics
(Vital Signs/ECG)



Electronic
Patient Record



Electronic
Prescription /
Medication
Dispensing



Patient
Admission



Patient Data
Management
System (PDMS)



Picture
Archiving &
Communication
System (PACS)



Video
Conferencing



Select your Computer Cart

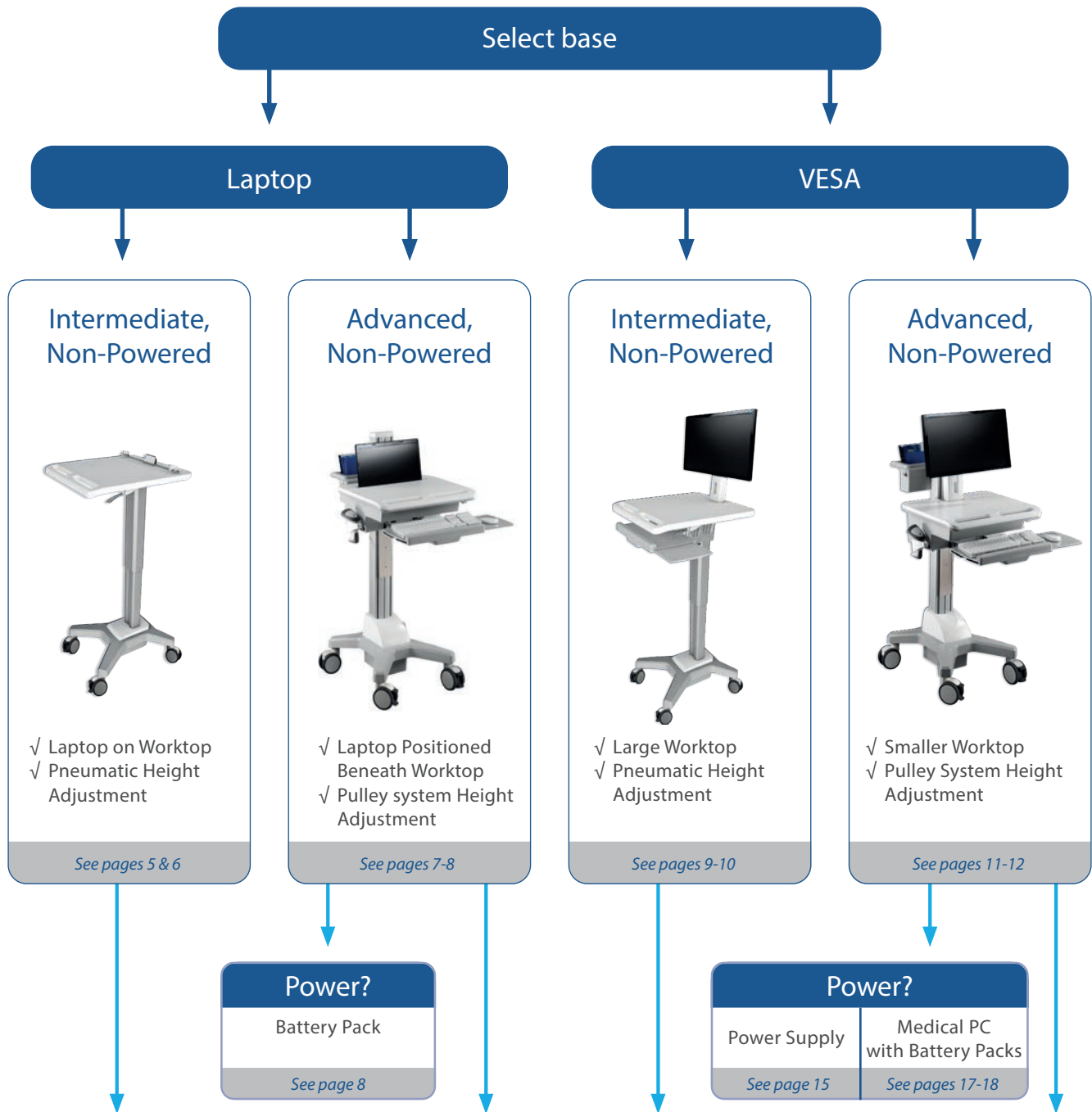

Accessories *See pages 21-32*

Practical examples

VESA Cart with MedEye medication dispensing solution
See pages 33-34

VESA Cart with various IT solutions
See pages 35-36

Laptop Cart - Intermediate, Non-Powered

Item 5AL/LC

Applications

- ✓ Electronic Patient Records
- ✓ Patient admission

Convenience

- ✓ Large worksurface
- ✓ Laptop supported on worktop with clamp to secure from theft
- ✓ Supports up to 10kg
- ✓ Configurable with accessories
- ✓ Optional keyboard tray



Hygienic

- ✓ Smooth surfaces
- ✓ Radiused edges assists cleaning

Services

- ✓ Delivered fully assembled & ready to use
- ✓ Comprehensive warranty & service options

Quality

- ✓ Durable aluminum & plastic parts
- ✓ Robust construction
- ✓ Anti-static castors

Ergonomics

- ✓ Lightweight construction to assist easy manoeuvrability
- ✓ Large worktop
- ✓ Easy height adjustment
- ✓ Ergonomically positioned handle at the front of the cart
- ✓ Twin wheel braked castors use a downward movement to set & release the brake
- ✓ No sharp edges



To set the brake, push the brake down from top to bottom with the foot.



To release the brake, push the brake down from top to bottom with the foot (same as for setting the brake).

Overview of product specifications		
Total load capacity	1 to 10 kg, more load capacity is optionally available	
Net weight	16.7 kg	
Worktop dimensions	550 x 580 mm, including handle	
Laptop fixation		
Laptop support	Display type	Laptop/notebook
	Maximum laptop width	17.3"



Storage bin with integrated handles. Needs to be ordered separately with a Laptop Cart, Intermediate, Non-Powered
Item 5AL/ST/BIN/H



Laptop clamp for securing laptop
Item 5AL/LPC

Dimensions

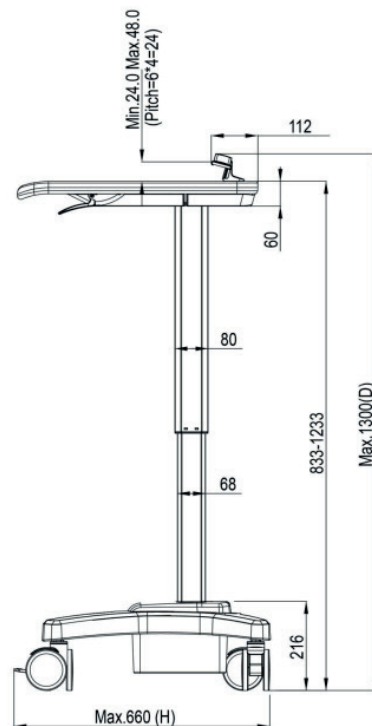
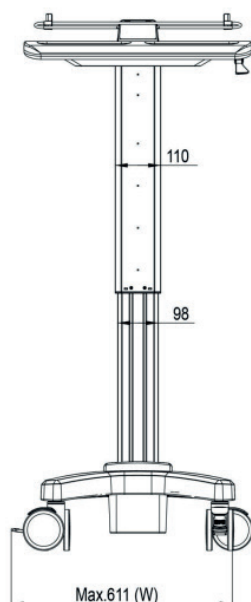
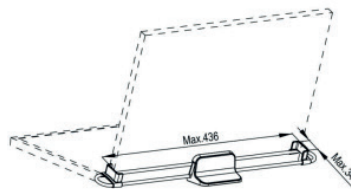
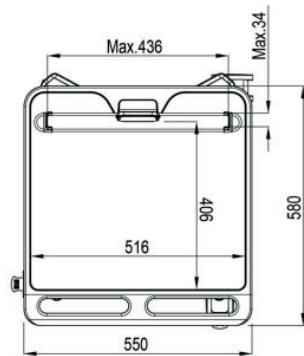

Laptop Cart - Advanced, Non-Powered

Item 5AL/LC/A

Applications

- √ Phlebotomy
- √ Electronic Patient Records
- √ Electronic Prescription / Medication Dispensing
- √ Patient Admission

Convenience

- √ Laptop is secured under the worktop, providing a large work area & concealing the keyboard
- √ Routinely equipped with a scanner & mouse holder & retractable power cable
- √ Configurable with a wide range of accessories
- √ Compatible with a battery pack, providing increased operation time
- √ Optional heavy duty height adjustment mechanism, suitable for use with drawers & medication cassettes



Laptop Cart fitted with optional plastic drawer unit (5AL/DR)

Hygienic

- √ Smooth surface
- √ Radiused edges assists cleaning

Services

- √ Delivered fully assembled & ready to use
- √ Comprehensive warranty & service options

Quality

- √ Durable aluminium & plastic parts
- √ Robust construction
- √ Anti-static castors
- √ Unique height-adjustment mechanism

Ergonomics

- √ Lightweight construction to assist easy manoeuvrability
- √ Easy height adjustment, adjustable to suit different weights
- √ Ergonomically positioned handle at the front of the cart
- √ Routinely equipped with an integrated handle at the rear of the cart
- √ Twin wheel braked castors use a downward movement to set & release the brake
- √ Pull out keyboard tray, can be tilted & features an integrated wrist support. Mouse tray is retractable for right / left hand use
- √ No sharp edges

Overview of product specifications		
Total load capacity	15 kg or 50 kg with heavy-duty column	
Net weight	29.5 kg	
Worktop dimensions	550 x 480 mm, including handle	
Laptop		
Laptop support	Display type	Laptop/notebook
	Maximum laptop width	17.3"
	Cable management option	Yes

Item 5AL/BAT/PACK

Battery pack

Battery pack: a unique, lightweight technology for more autonomy at a low TCO (Total Cost Ownership).

- ✓ Capacity: 180Wh / 50,000mAh
- ✓ Weight: 1,300 grams
- ✓ Charging time: 6-8 hours
- ✓ USB outputs: 2x 5V 2.1A / 2x 5V 1.0A
- ✓ DC outputs: 12V 2.5A / 20V 3.0A

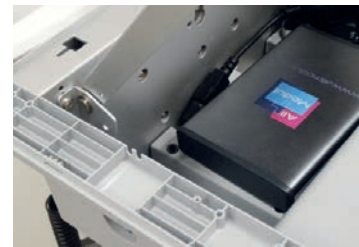

Item 5AL/RPC

Retractable Power Cable



Item 5AL/PA

Power Adapter



Dimensions

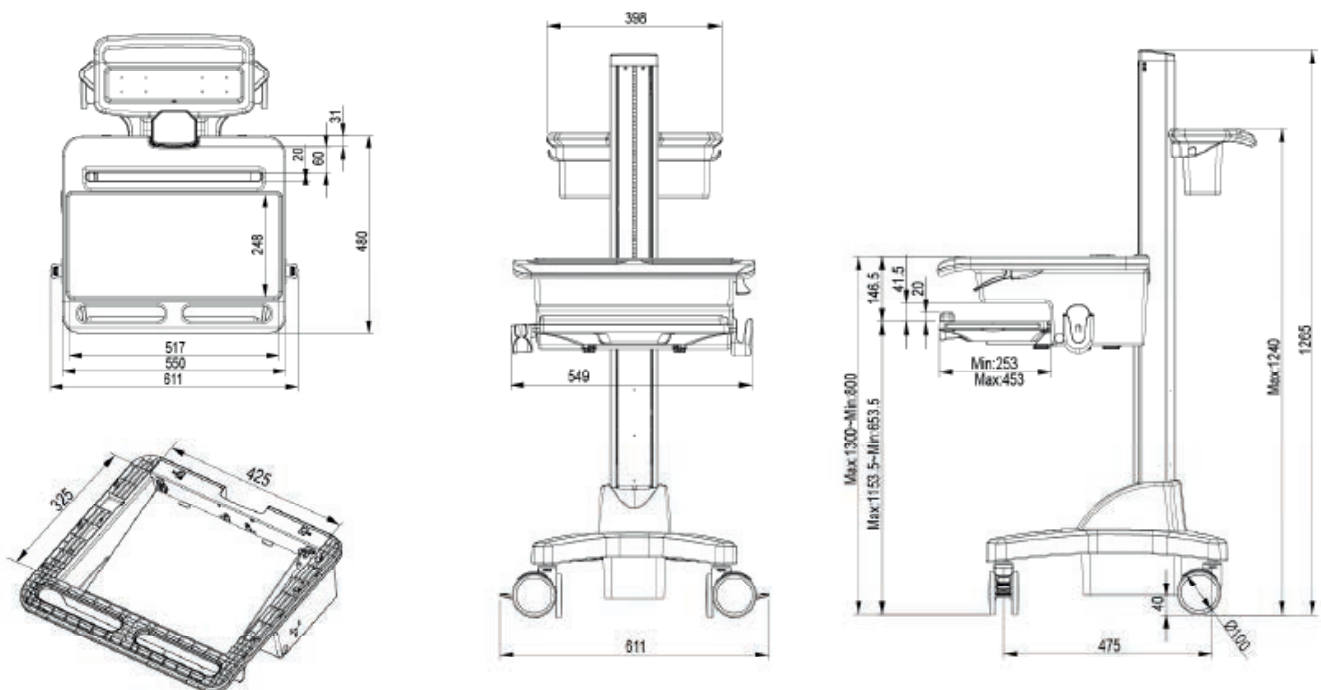

VESA Cart - Intermediate, Non-Powered

Item 5AL/CC/VM

Designed for the healthcare industry

- ✓ The VESA Cart, Intermediate, Non-Powered Cart is designed to meet our customers' needs for a simple, high-quality, lightweight and inexpensive product
- ✓ The cart is not only easy to use, it also features perfect colour coordination, a streamlined style and a solid structure design for all medical applications.
- ✓ The height of the cart is easy to adjust and the worktop has a lifting range of 83.30 cm to 123.30 cm, suitable for users of any height. In addition to the standard worktop, we can also make customised worktops.

This means we can convert the product into, for example, a height-adjustable cart that can be used for blood pressure measurements or other medical applications.

- ✓ The product design features a nice colour configuration and solid construction that is capable of supporting 1-10 kg or 10-20 kg of weight.
- ✓ The cart has dual wheels, with the front 2 wheels being braked. Thanks to its light weight and dual wheels, the cart is very easy to manoeuvre.

Applications

- ✓ Electronic Patient Record
- ✓ Patient admission

VESA cart fitted with optional keyboard tray (Item 5AL/KT).

Convenience

- ✓ Large worktop
- ✓ Supports up to 10kg
- ✓ Configurable with accessories
- ✓ Optional keyboard tray



Hygienic

- ✓ Smooth surfaces
- ✓ Radiused edges assists cleaning

Services

- ✓ Delivered fully assembled & ready to use
- ✓ Comprehensive warranty & service options

Quality

- ✓ Durable aluminium & plastic parts
- ✓ Robust construction
- ✓ Anti-static castors

Ergonomics

- ✓ Lightweight construction to assist easy manoeuvrability
- ✓ Large worktop
- ✓ Easy height adjustment
- ✓ Ergonomically positioned handle at the front of the cart

- ✓ Twin wheel braked castors use a downward movement to set & release the brake
- ✓ No sharp edges

Overview of product specifications		
Total load capacity	7.5 to 10 kg, more load capacity is optionally available	
Net weight	18.7 kg	
Worktop dimensions	550 x 580 mm, including handle	
Display system		
Monitor column	Height adjustment	130 mm (5.12")
	Resistance adjustable by weight	Includes Allen key
	Cable management option	Yes
Universal VESA holder	Tiltable	-5° (down) ~ +25° (up)
	Rotation	360°
	Resistance adjustable by weight	Includes Allen key
Display support	VESA monitor mount	100x100 mm / 75x75 mm
	Display type	1 PC
	Panel size support	Up to 24"
	Weight load	6-12 kg



Scanner holder
(Item 5AL/COW/BCS/H) with
special clamp for the VESA cart
(Item 5AL/COW/SHC).

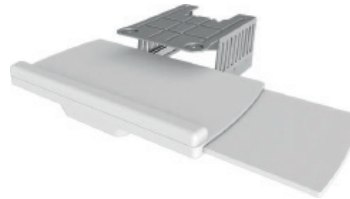

Optional keyboard tray
for the VESA carts
Item 5AL/KT

Dimensions

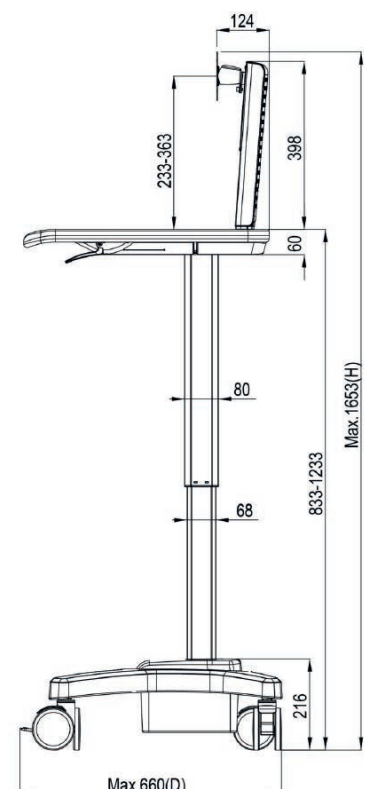
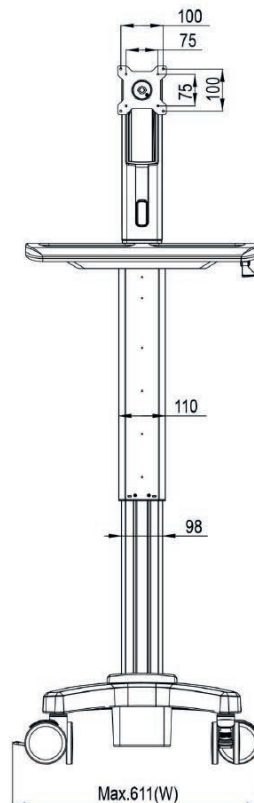
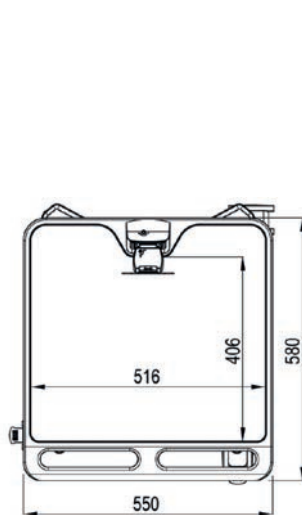

VESA Cart - Advanced, Non-Powered

Item 5AL/CC/A/VM

Applications

- ✓ Phlebotomy
- ✓ Diagnostics (Vital Signs / ECG)
- ✓ Electronic Patient Records
- ✓ Electronic Prescription / Medication Dispensing
- ✓ Patient Admission
- ✓ Patient Data Management System (PDMS)
- ✓ Picture Archiving & Communication System (PACS)
- ✓ Video Conferencing

Convenience

- ✓ Supplied with a scanner & mouse holder & retractable power cable
- ✓ Configurable with a wide range of accessories
- ✓ Compatible with a battery pack, providing increased operation time
- ✓ Suitable for use with DT Research All-In-One (AIO) PC
- ✓ Optional heavy duty height adjustment mechanism, suitable for use with drawers & medication cassettes



Hygienic

- ✓ Smooth surfaces
- ✓ Radiused edges assists cleaning

Services

- ✓ Delivered fully assembled & ready to use
- ✓ Comprehensive warranty & service options

Quality

- ✓ Durable aluminium & plastic parts
- ✓ Robust construction
- ✓ Anti-static castors
- ✓ Unique height-adjustment mechanism

Ergonomics

- ✓ Lightweight construction to assist easy manoeuvrability
- ✓ Easy height adjustment, adjustable to suit different weights
- ✓ Monitor height can be set independently, tiltable for optimal viewing
- ✓ Ergonomically positioned handle at the front of the cart
- ✓ Integrated handle at the rear of the cart
- ✓ Twin wheel braked castors use a downward movement to set & release the brake
- ✓ Pull out keyboard tray, can be tilted & features an integrated wrist support. Mouse tray is retractable for right / left hand use
- ✓ No sharp edges

Overview of product specifications		
Total load capacity	15 kg or 50 kg with Heavy Duty column	
Net weight	31 kg	
Worktop dimensions	550 x 480 mm, including handle	
Display system		
Monitor column	Height-adjustable	130 mm (5.12")
	Resistance adjustable by weight	Includes Allen key
	Cable management option	Yes
Universal VESA holder	Tiltable	-5° (down) ~ +25° (up)
	Rotation	360°
	Resistance adjustable by weight	Includes Allen key
Display support	VESA monitor mount	100x100 mm/75x75 mm
	Display type	Single monitor
	Panel size support	Up to 24"
	Weight load	4-12 kg

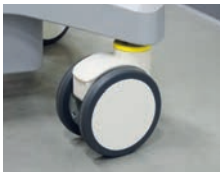

Anti-static castors

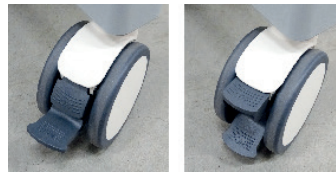

Unique braking system



Mouse holder with a slot for the USB cable of a medical mouse

Dimensions

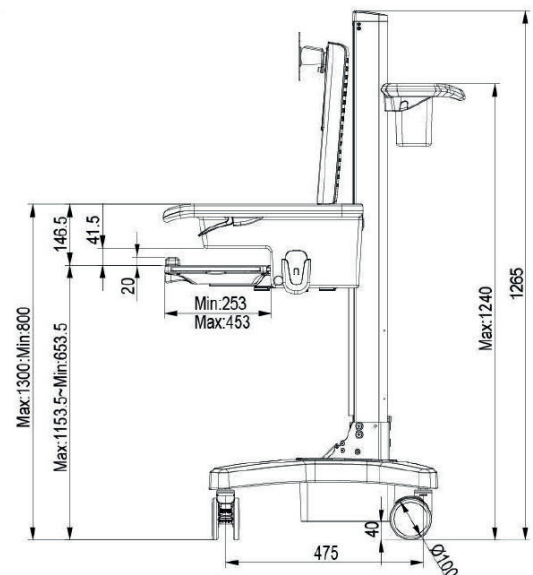
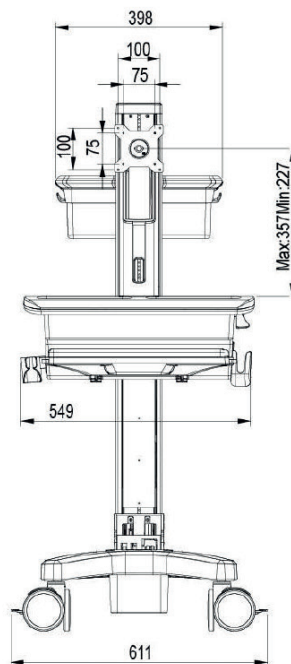
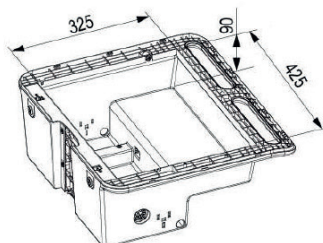
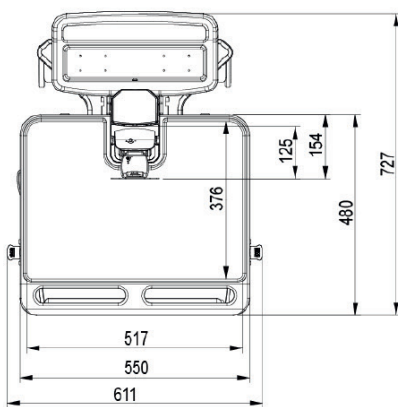

VESA Cart - Advanced, Powered

Item 5AL/CC/A/PO/VM

Applications

- ✓ Phlebotomy
- ✓ Diagnostics (Vital Signs / ECG)
- ✓ Electronic Patient Records
- ✓ Electronic Prescription / Medication Dispensing
- ✓ Patient Admission
- ✓ Patient Data Management System (PDMS)
- ✓ Picture Archiving & Communication System (PACS)
- ✓ Video Conferencing

Convenience

- ✓ Supplied with a scanner & mouse holder & retractable power cable
- ✓ Configurable with a wide range of accessories
- ✓ Compatible with a battery pack, providing increased operation time
- ✓ Optional heavy duty height adjustment mechanism, suitable for use with drawers & medication cassettes



Hygienic

- ✓ Smooth surfaces
- ✓ Radiused edges assists cleaning
- ✓ Fanless

Services

- ✓ Delivered fully assembled & ready to use
- ✓ Comprehensive warranty & service options

Quality

- ✓ Durable aluminium & plastic parts
- ✓ Robust construction
- ✓ Anti-static castors
- ✓ Unique height-adjustment mechanism

Ergonomics

- ✓ Lightweight construction to assist easy manoeuvrability
- ✓ Easy height adjustment, adjustable to suit different weights
- ✓ Monitor height can be set independently, tiltable for optimal viewing
- ✓ Ergonomically positioned handle at the front of the cart
- ✓ Integrated handle at the rear of the cart
- ✓ Twin wheel braked castors use a downward movement to set & release the brake
- ✓ Pull out keyboard tray, can be tilted & features an integrated wrist support. Mouse tray is retractable for right / left hand use
- ✓ No sharp edges

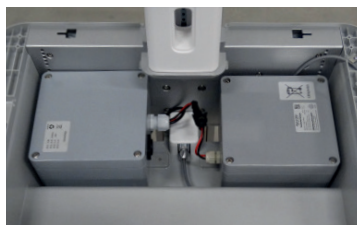

Item 5AL/BAT/PC

VESA cart power supply

VESA cart power supply: a unique, lightweight technology for a high degree of autonomy at a low TCO.

- ✓ Ideal for your medical IT workstations.

- ✓ Lightweight, fanless.
- ✓ Capacity: 520 Whr
- ✓ Weight: 6 kg
- ✓ Charging time: 3 to 4 hours
- ✓ Input: 110V or 230V
- ✓ Output: 12V / 19V / 48V

Overview of product specifications		
Total load capacity	15 kg or 50 kg with Heavy Duty column	
Net weight	37 kg	
Worktop dimensions	550 x 480 mm, including handle	
Display system		
Monitor column	Height-adjustable	130 mm (5.12")
	Resistance adjustable by weight	Includes Allen key
	Cable management option	Yes
Universal VESA holder	Tiltable	-5° (down) ~ +25° (up)
	Rotation	360°
	Resistance adjustable by weight	Includes Allen key
Display support	VESA monitor mount	100x100 mm / 75x75 mm VESA
	Display type	Single monitor
	Panel size support	Up to 24"
	Weight load	4-12 kg
Power supply		
Type	Internal supply	Battery capacity 520 Whr
Ports	Input	110V or 230V
	Output	12V / 19V / 48V

Dimensions

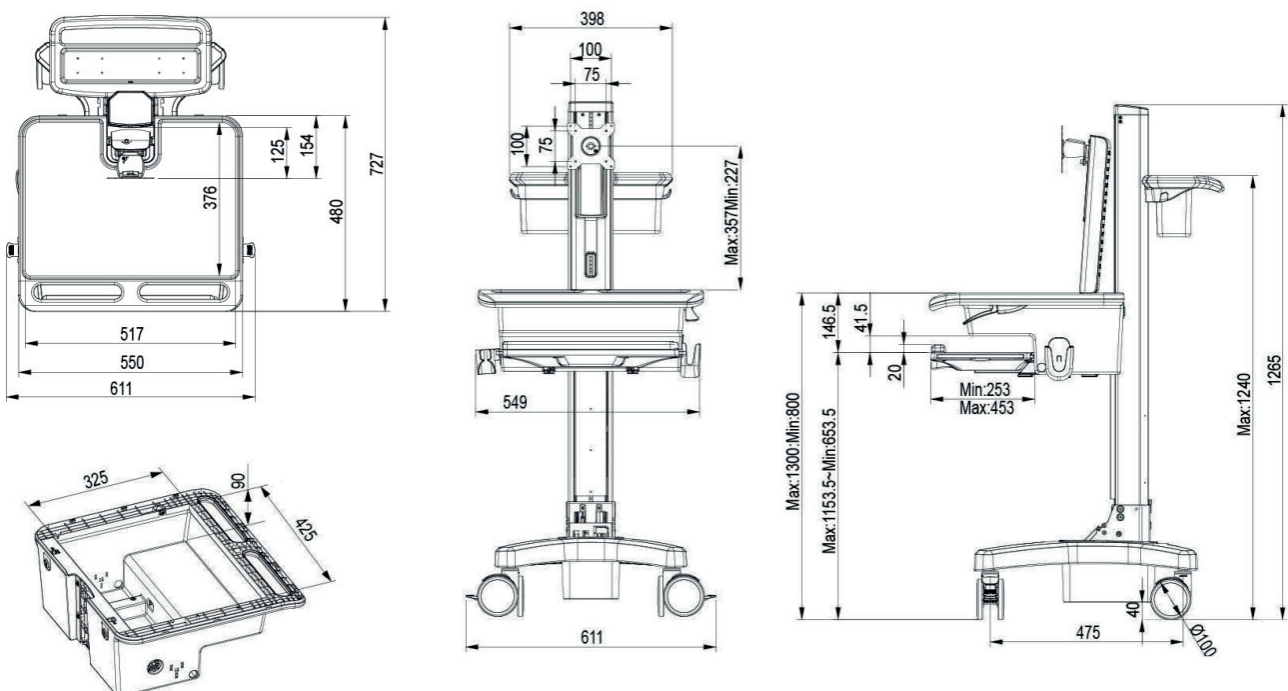

Powered VESA Cart

Internal Power Supply



A powered Mobile Computer Cart can be outfitted with LED lighting for use during the night shift

Computer cart power supply

A unique, light-weight technology for a high degree of autonomy for a low TCO.

- ✓ Ideal for your medical IT workstations.
- ✓ Lightweight, fanless.
- ✓ Capacity: 520 Whr
- ✓ Weight: 6 kg
- ✓ Charging time: 3 to 4 hours
- ✓ Input: 110V or 230V
- ✓ Output: 12v/19v/48v



Item 5AL/BAT Battery



Item 5AL/DIS/ST Distribution station



Item 5AL/BAT/CH Charger



Item 5AL/BAT/IND Battery indicator



DT Research 504

Medical AIO PC for Powered Mobile Computer Carts

The DT Research medical grade all-in-one system integrates a 21,5-inch, 24-inch or 27-inch TFT-LCD with an energy efficient Intel® Pentium® Gold or Core™ i platform in a fanless, slim, bacteria-resistant enclosure. Designed for medical and healthcare applications, this LCD-integrated system provides space-saving solutions for health professionals to monitor, record and retrieve patient information as well as other point-of-care applications. The built-in Wi-Fi and Bluetooth connections also make data access efficient and optimizes staff workflow.

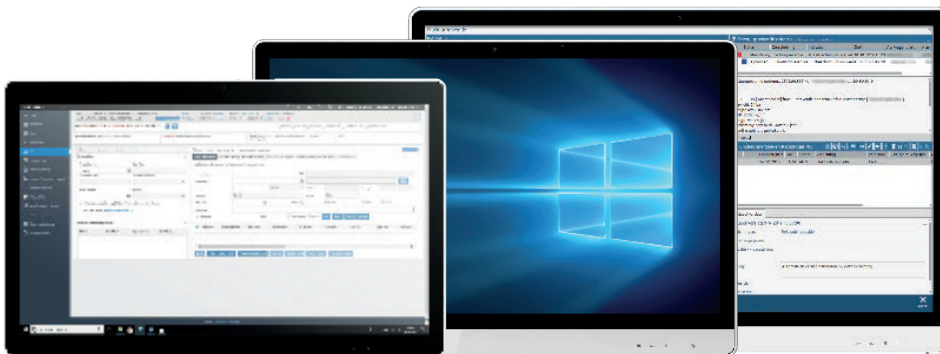

21,5" 518 x 324 x 40 mm
(HxWxD)
Weight: 6.26 kg

24" 370.5 x 567 x 45.2 mm
(HxWxD)
Weight: 8 kg

27" 411.8 x 639.1 x 45 mm
(HxWxD)
Weight: 10.5 kg

Features DT Research 502, 504 & 507 medical AIO PC's

- √ 21.5", 24" or 27" capacitive touchscreen
- √ i5, i7 of Pentium processor
- √ Microsoft® Windows® 10/11 IoT Enterprise or Ubuntu operating system
- √ Energy Star 8.0 certified (504T)
- √ Elegant all-in-one, slim, fanless design with antimicrobial enclosure
- √ IP65 rated front panel with IPX2 rated enclosure
- √ VESA-mountable for flexibility in mounting and placement
- √ RAM 8GB to 32 GB (502) / 64GB (504 & 507)
- √ Display Resolution 1920 x 1080 (21,5" & 24") / 1920 x 1080 or 3840 x 2160 (optional 27")
- √ Storage 256GB to 4TB Flash
- √ WLAN, Bluetooth, Wi-Fi
- √ USB 3.0 x 4 ((ESD protection: ±17KV by air, ±12KV by contact)
- √ USB 2.0 x 2 (ESD protection: ±18KV by air, ±12KV by contact)
- √ 3 x COM-port (optional for the 502), 1 x audio-out, 1 x HDMI-out, 1 x DC-in
- √ 2 x ethernet (ESD protection: ±30KV by air, ±30KV by contact)
- √ 1 x Potential Equalization Conductor (optional)
- √ Temperature: Operation: 0°C to 40°C; Storage: -20°C to 60°C
- √ Humidity 0% – 90% non-condensing
- √ Smartcard/CAC-lezer (optioneel voor de 504 & 507)
- √ Major options: 4K resolution screen (507), Integrated UPS battery, Front camera, Smart card/CAC reader, Single/dual frequency NFC/RFID reader

All to do

- √ Do you want to extend your Mobile Computer Cart's service life with maintenance?
- √ Are you missing an SLA partner?
- √ Do you want to create more sustainability?
- √ Do you want to change your Worktop?
- √ Is your power supply due for replacement?
- √ Do you want to switch from a fixed to an interchangeable power supply?
- √ Do you want to refurbish your entire solution?

As a specialist in medical IT workstations, we are happy to help you. Just ask us for advice.

Powered Mobile Computer Cart monitors

The energy-efficient DT Research 504 medical All-in-One (AIO) PC is eminently suited for use on the powered cart.

We can also supply other medical monitors.



DT Research medical AIO PC 581, 582 & 584

With Internal Battery Cells

Powered by a powerful Intel® Pentium® Gold or Core™ i processor, the 581T/582T/584T All-in-One Medical-Cart Computer features a 19.5"/22"/24" easy-to-read display to provide at-a-glance examination to ensure efficient operation. With the optional hot-swappable batteries, patient data can be managed fluidly without operations being interrupted due to the act of replacing batteries, while the VESA standard mounting design makes installation an effortless task. The built-in Wi-Fi and other optional data-capture modules further improve the point-of-care process. With these extensive features, the 581T/582T/584T is ideal for hospitals and clinics in any point-of-care scenarios.

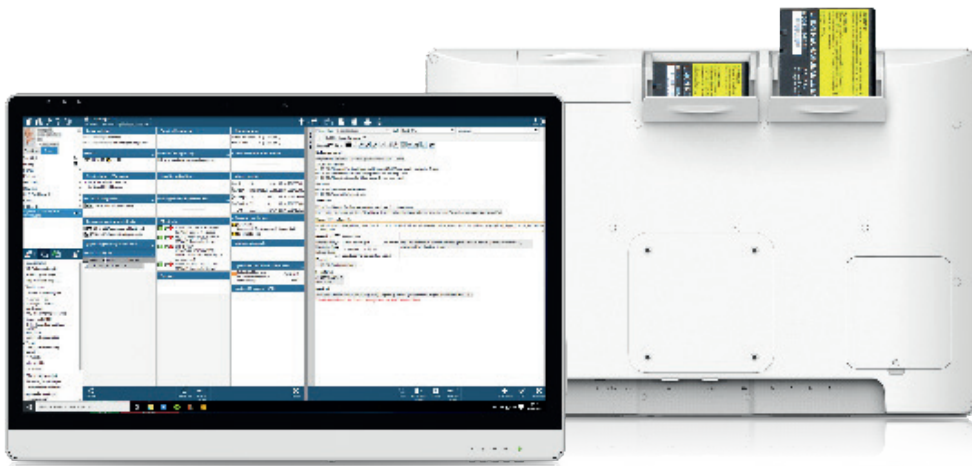

- | | | | |
|---|---------------------------------------|---|----------------------|
| A | USB 2.0 (582 / 584)
USB 3.0 (581) | F | COM ports (optional) |
| B | On/off button and
function buttons | G | HDMI input |
| C | DC-outputs | H | USB 3.0 |
| D | DC-inputs | I | Speakers |
| E | Ethernet port | J | Reading light |
| | | K | Reading light power |

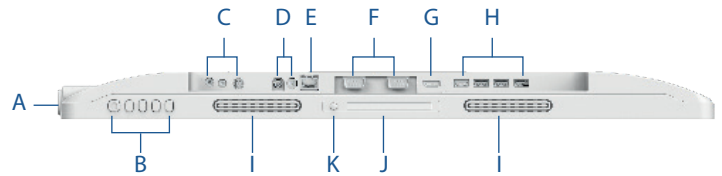

Features DT Research 581, 582 & 584 medical AIO PC with internal battery cells

- ✓ ANSI/AAMI ES60601-1 certified with antimicrobial enclosure
- ✓ Three integrated hot-swappable batteries (582 / 584) or two batteries (581)
- ✓ High resolution 19,5" / 22" / 24" capacitive touchscreen
- ✓ i5, i7, i9 of Pentium processor
- ✓ Energy Star 8.0 certified (582)
- ✓ Fanless, IP65-rated front panel, IPX2-rated enclosure
- ✓ Built-in LED reading light
- ✓ HDMI video-out, support up to 4K UHD resolution
- ✓ VESA compatibility to maximize installation flexibility
- ✓ RAM 8GB up to 32 GB (581) / 64GB (582 & 584)
- ✓ Storage 256GB / 4TB Flash (581: 64GB / 2TB Flash)
- ✓ Microsoft® Windows® 10/11 IoT Enterprise operating system or Ubuntu
- ✓ Display resolution 1920 x 1080
- ✓ WLAN, Bluetooth
- ✓ 2 USB 2.0 ports en 4 USB 3.0 ports (6 x 581), 1 COM Port, 1x HDMI-out, DC-in en DC-out.
- ✓ AC/DC-adapter
- ✓ 581: frontcamera (5M optional), Smart card reader (optional CAC), RFID reader (NFC optional)
- ✓ 582 & 584 options: Power supply outputs, Full-HD frontcamera, RFID-reader, Smart card-reader
- ✓ Battery pack DR202 Li-ionbattery; 90Wh, 8250mAh (optional)
- ✓ Weight 19,5" without batteries 4.7 kg, including batteries 5.7 kg
- ✓ Weight 22" without batteries 5.7 kg, including batteries 7.2 kg
- ✓ Weight 24" without batteries 6.4 kg, including batteries 7,9 kg



22" thin bezel medical AIO PC with internal batteries

346 x 517 x 40 mm (HxWxD)

- ✓ Storage possibilities: Up to 1TB Flash
- ✓ RAM: 8GB up to 16GB
- ✓ Display resolution: 1920 x 1080
- ✓ USB-ports: USB 2.0 x 2, USB 3.0 x 4
- ✓ 4 COM Ports
- ✓ Front panel: IP65; Enclosure: IPX2
- ✓ 2 HDMI-out (1.4a)



24" thin bezel medical AIO PC with internal batteries

371 x 564 x 41 mm (HxWxD)

- ✓ Storage possibilities: Up to 1TB Flash
- ✓ RAM: 8GB up to 16GB
- ✓ Display resolution: 1920 x 1080
- ✓ USB-ports: USB 2.0 x 2, USB 3.0 x 4
- ✓ 4 COM Ports
- ✓ Front panel: IP65; Enclosure: IPX2
- ✓ 2 HDMI-out (1.4a)

Item 5AL/24/AIO/PC



Item 5AL/AIO/BAT
Battery cells for AIO PCs



Item 5AL/AIO/BAT/CH
Battery charger for AIO PC

External battery charges up to six batteries.



DT 724 Medical Grade Monitor

With Internal Battery Cells

The DT Research 722M/ 724M Medical Grade Monitor integrates a 22" or 24" screen and hot-swappable batteries in a slim, mountable and antimicrobial package to facilitate the system integration for healthcare applications. With built-in LED reading light, Wi-Fi antennas as well as optional data-capture modules, this Medical Grade Monitor supports to pair with personal computers, embedded controllers, or thin clients for health professionals to manage information. The unique power outlets (DC-output) can provide a thin client with the needed current.

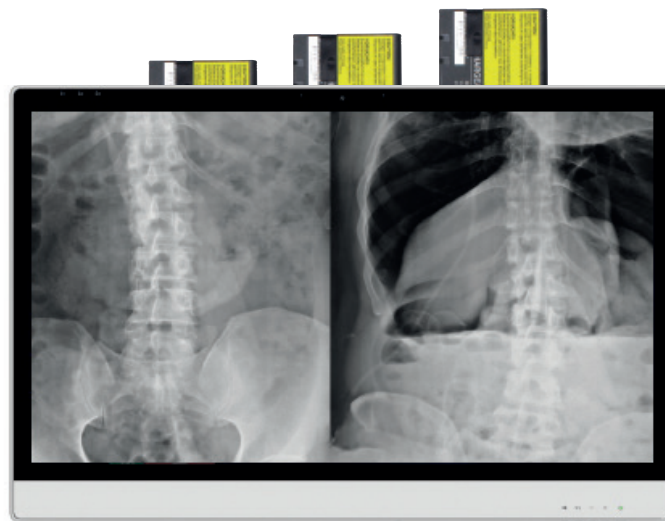

- | | | | |
|---|------------------------------------|---|--|
| A | USB 2.0 | H | USB 3.0 |
| B | On/off button and function buttons | I | USB Type-B for touch screen connection |
| C | DC-outputs | J | Wi-Fi antennas |
| D | DC-inputs | K | Speakers |
| E | USB Type-B input | L | Reading light |
| F | COM ports (option) | M | Reading light power |
| G | HDMI input | | |

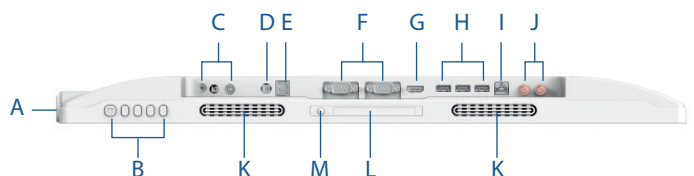

Features DT Research 724 medical monitor

- ✓ ANSI/AAMI ES60601-1 certified with antimicrobial enclosure
- ✓ High resolution 22" or 24" capacitive touchscreen
- ✓ Full-HD (1920 x 1080) resolution
- ✓ Three integrated hot-swappable batteries
- ✓ Fanless
- ✓ Medical monitor with power output which can provide a thin client with current. Power supply outputs - 12V, 15V and 19V.
- ✓ Built-in wifi-antennas, LED reading light and speakers.
- ✓ VESA-mountable for flexibility in mounting
- ✓ Display resolution 1920 x 1080
- ✓ Viewing Angle: horizontal 89 degree, vertical 89 degree
- ✓ Number of colours 16.7M
- ✓ Brightness 250 cd/m²
- ✓ Response Time 5 ms. (22") / 16 ms. (24")
- ✓ Control button: 1 screen on/off button, 1 menu button, 1 auto/exit button, 2 up/down buttons, and 1 reading light on/off button
- ✓ Operation: 0°C – 40°C; Storage: -20°C – 60°C
- ✓ Humidity 0% – 90% non-condensing
- ✓ Optional: Power supply outputs, Full-HD camera, RFID reader, Smart cart reader

DT 139 Medical Micro PC

The DT Research 139M Medical Micro PC offers the integration of a high performance yet energy-efficient Intel® Pentium® Gold or Core™ i computing platform in a fanless, robust and compact design. The anti-microbial enclosure is complemented by display outputs, USB, RS232, networking and audio ports, making this Medical Micro PC ideal for space-saving and clean-sensitive healthcare applications.

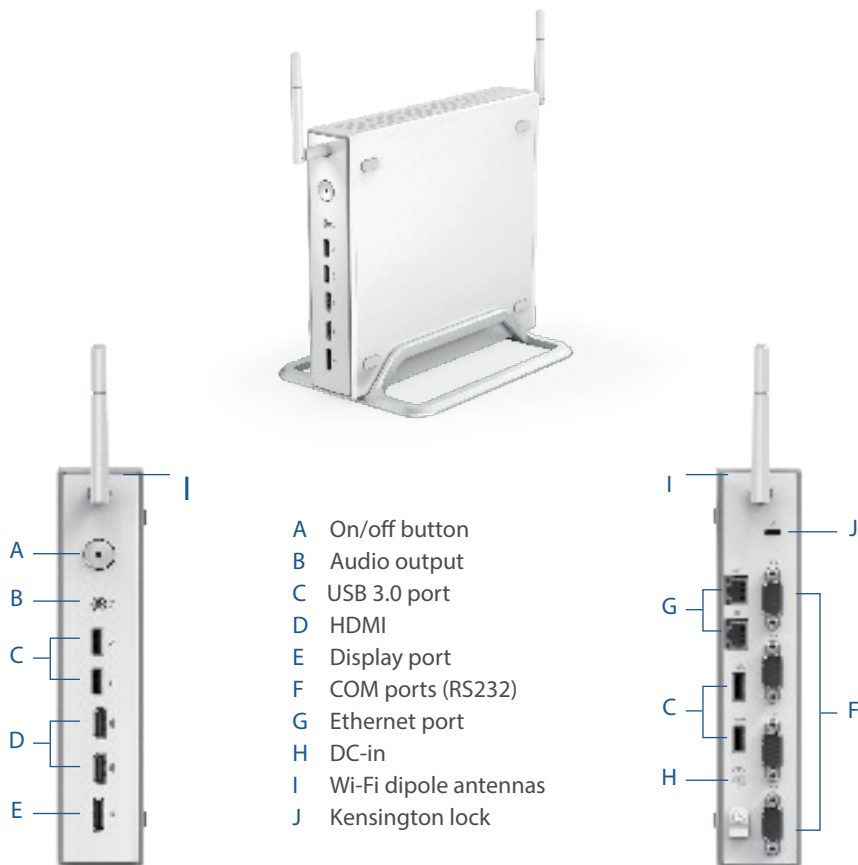

Features DT Research 139 Medical Micro PC

- ✓ ANSI/AAMI ES60601-1 certified with antimicrobial enclosure
- ✓ Intel® 10e generation Pentium® Gold- of Core™ i-processor
- ✓ Microsoft® Windows® 10/11 IoT Enterprise or Ubuntu operating system
- ✓ Fanless, compact and robust design
- ✓ Dual SSD slots, support RAID 0/RAID 1
- ✓ Dual RAM slots, up to 64GB
- ✓ Aluminium alloy
- ✓ NIST-compatible BIOS available
- ✓ Multiple video outputs – HDMI x 2 and DisplayPort x 1
- ✓ Internal 802.11 wireless adapter with dual antennas
- ✓ VESA-mountable for flexibility in mounting and deployment
- ✓ Intel® Pentium® Gold-G6400T, i5, i7 of i9
- ✓ RAM 8GB up to 64GB (dual-slot)
- ✓ Storage 256GB up to 4TB Flash (dual-slot, supports RAID 0/RAID 1)
- ✓ Weight 2,1 kg
- ✓ Dimensions: (H x B x D) 202 x 43,5 x 232 mm (without the antennas)
- ✓ Temperature: Operation: -10°C tot 50°C; Storage: -20°C tot 60°C
- ✓ Humidity 0% – 90% non-condensing

VESA Mounts / Holders

All you need to know

Bristol Maid offers a wide range of IT solutions for the healthcare industry, including Mobile Computer Carts.

We can customize your Mobile Computer Cart according to your wishes.

Do you have a new project or do you need support for your existing Mobile Computer Cart?

With our high-quality product range at attractive prices, we can quickly help you.

We can fully equip your laptop cart or computer cart with a hospital monitor, medical PC, medical keyboard or medical mouse to fit your needs.

We will work with you to find the optimal solution for your Mobile Computer Cart requirements.

Item 5AL/VESA/MH/HL VESA high/low adjustable monitor holder

VESA carts are routinely equipped with this monitor holder.



Item 5AL/VESA/MH/2SBS VESA Dual mount monitor holder for two side-by-side monitors

This dual mount VESA holder is perfect for the placement of two side-by-side monitors.

The monitors can move independently of each other.

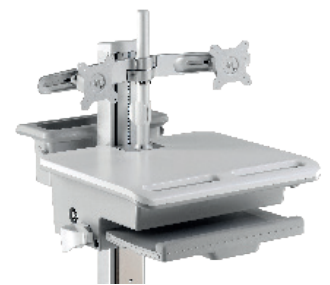

Item 5AL/VESA/MH/2VS VESA Dual mount monitor holder for two vertically stacked monitors

This VESA dual mount monitor holder has room for two vertically stacked (top and bottom) monitors. The monitors cannot move independently of each other. The sturdy monitor column has no moving parts. Ideal for a cleanroom environment, among other uses.



Item 5AL/VESA/MH/CR VESA monitor holder for use in cleanrooms.

The sturdy monitor column with VESA mounting option has no moving parts. Ideal for a cleanroom environment.



Item 5AL/VESA/MH VESA monitor holder

VESA carts are routinely equipped with this VESA monitor holder.





Item 5AL/VESA/MC/HD
Heavy-duty monitor column

Sturdy monitor column that also serves as a cable conduit. The adjustable VESA holder (Item 5AL/VESA/MH) easily fits in the column opening. Accessories can be hung from the column.



Item 5AL/VESA/SW
Swivel attachment

Swivel attachment for placement between the Worktop and adjustable monitor holder. This allows the monitor to be rotated without having to move the Mobile Computer Cart. Also ideal for creating more visibility when walking or for quickly sharing information with a colleague during admission or treatment.



Item 5AL/TAB/H
Tablet holder

This tablet holder is suitable for all types of tablets. The angle is adjustable.

More to know

Medical tablets

Entry-level 10" tablet

We supply tablets from 10". Always with the most current Intel processors.



- ✓ 10.1" or 13.3" multi-touch screen, 1000 nits, digital pen support
- ✓ Microsoft® Windows® 10 IoT Enterprise or Ubuntu operating system
- ✓ Docking keyboard option for 2-in-1 (tablet/laptop) applications
- ✓ ANSI/AAMI ES60601-1 certified with antimicrobial enclosure
- ✓ IP65 and MIL-STD-810G certified
- ✓ NIST compliant BIOS available
- ✓ Hot swappable battery pack
- ✓ Built-in front and back cameras
- ✓ Built-in smart card/CAC reader
- ✓ Barcode scanner (Optional)
- ✓ Single/dual frequency NFC/RFID reader (Optional)
- ✓ 4G LTE/AWS (Optional)

Holders & Scanners

All to know Scanner holders

VESA holders

Most barcodes canner holders that are positioned next to an AIO PC or monitor are mounted with a VESA holder.

The lightweight scanner holders are mounted onto the VESA holder of the screen. This way the scanner are easily accessible for users. Available for wireless scanners with docking stations as USB-wired handscanners.

Every holder has its own advantages. Let our specialist help and advise.

Standard holder

As standard the Mobile Computer Carts are supplied with a plastic barcodescanner holder. It is attached to the body of the cart.



Item 5AL/COW/BCS/H

Item 5AL/LAP/BCS/H

Barcode scanner holder for laptop carts

Epoxy-coated steel

This scanner holder can be used on laptop computer carts. The holder is mounted onto the Worktop. A host of scanner solutions can be mounted on the holder, provided that the scanner has a self-charger (docking station), as seen in the image.



Item 5AL/VESA/BCS/H

VESA barcode scanner holder

Aluminum

This lightweight scanner is mounted onto the VESA monitor holder, making the scanner easily accessible to the user. Available for both wireless scanners with docking station and USB-wired handheld scanners. An additional part is needed for hanging USB handheld scanners (Item 5AL/SCAN/USB/H).



Item 5AL/SCAN/USB/H

Barcode scanner holder for USB scanner

Aluminium, white

For USB wired scanners without a docking station. The scanner can be positioned on the left or right side of the monitor. To use this solution it must be mounted on a scannerholder with VESA (Item no. 5AL/VESA/BCS/H).



Item 5AL/BCS/MON/D/H

Double barcode scanner holder behind the display

Aluminium, white

The barcode scanner is accessible to the right and left of the monitor.



Single scanner or accessory holder for mounting behind the monitor

Aluminium, white

Onto this holder a scanner or accessory can be mounted. There is a holder available for the left side (Item 5AL/BCS/MON/L) and the right side (Item 5AL/BCS/MON/R).



Leftside holder



Item 5AL/BCS/MON/T
Tilted barcode scanner holder behind the monitor
Aluminium, white

The barcode scanner is accessible to the right of the monitor. Ideal for installing cradles.



Item 5AL/SCAN/ST/M
Barcode scanner holder
Aluminium, gray

Scanner docking stations can be mounted on the holder. The gray colour of the holder matches the body of the Mobile Computer Carts well.



Item 5AL/MED/E/PRIN
Medeye and printer holder
Aluminium, gray

A Medeye or (label) printer can be mounted onto the holder. The grey colour of the holder fits well to the body of the Mobile Computer Carts.



Item 5AL/PRIN/MON
Printer holder for mounting behind the monitor
Aluminium, white

The printer holder is mounted next to the monitor column. Printer useables are easily changed thanks to the tilted shape of the holder.



Item 5AL/PRIN/PRO
Printer protector for use with the holder behind the monitor
Aluminium, white

The protector can prevent accidental damage caused to the printer.

All you need to know Barcode scanners

All round delivery

We supply all common Zebra and Datalogic USB-wired or wireless handheld barcode scanners.

RFID scanning

RFID employee ID card readers can also be used on our Mobile Computer Carts.
See page 36.



We are a Zebra business partner



We are a Datalogic business partner

Accessories

Did you know?

That we can customize your Mobile Computer Carts from A to Z to fit your needs?

Item 5AL/AC/RAIL
Reinforced accessory rail
Stainless steel

Different mounting methods are required for each accessory. A solution can be found for every accessory. Ask us for advice.

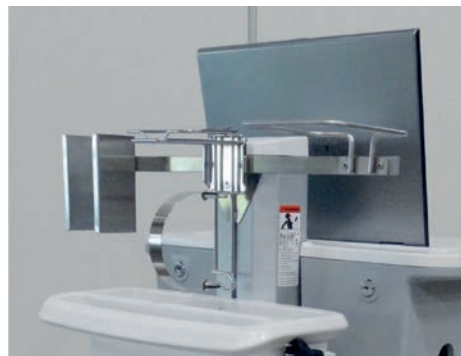

Item 5AL/DDH
Disinfection dispenser holder
82 x 80 x 203 mm (WxDxH)

Item 5AL/R/DDH
Refillable disinfection dispenser holds up to 500ml



Item 5AL/DIS/M
Hand alcohol/soap dispenser 500 ml with catch basin
80 x 80 x 320 mm (WxDxH), including elbow operation

Item 5AL/DIS/L
Hand alcohol/soap dispenser 1000 ml with catch basin
90 x 90 x 370 mm (WxDxH), including elbow operation



Item 5AL/SDH
Soap dispenser holder
Stainless steel

Holder for soap/disinfectants.





Item 5AL/GBH
Glove box holder



Item 5AL/GBS/1
Glove box system
262 x 107 x 152 mm (WxDxH)
Off-white ABS plastic.

This glove box holder fits almost any size of glove box. With a maximum measurement of 245 x 145 x 80 mm (WxDxH).



Item 5AL/WB
Waste bin
260 x 200 x 365 mm (WxDxH)
White polypropylene waste bin in an off-white, Rilsan-coated frame.

The waste bin with holder can be easily hung on the accessory rail without any tools.

The accessory rail must be ordered separately.



Item 5AL/KO/WB
Knee-operable waste bin Wally 8 litre
220 x 220 x 360 mm (WxDxH)
Plastic waste bin, 8 litre capacity.

Operable with the knee for hygienic purposes. The bin comes with an inner removable bin with brackets for fixing the waste bags.



Item 5AL/CWH
Cleaning wipes holder
Stainless steel

Holder for various containers of cleaning wipes.

More to know Plastic accessory system

Glove box system

For use on Mobile Computer Carts where there is a DIN rail (*Item 5AL/GBS/DIN*) available.

Next to the single glove box holder there is also a holder for three boxes available. (*Item no. 5AL/GBS/3*).

For the different sizes (XS up to XL) stickers will be provided. When the stickers need a refreshment they can be re-ordered. (*Art. no. 5AL/GBH/LAB*).



Disinfection dispenser holder

The holder is made of durable PP and is easily cleaned with soap and detergents up to 120 degrees.

Soap dispensers with a diameter up to 70 mm will fit perfectly into this holder.

Mount the holder with the DIN brackets onto an accessory rail.

Accessories

All to know Accessories

Mobile Computer Carts

All accessories are suitable for the Advanced Mobile Computer Cart.

A limited number of accessories are available for the Laptop Cart, Immediate.

Stainless steel holders

We supply many types of stainless steel holders. Each healthcare facility has its own requirements, we are happy to help and advise.

Diagnostic equipment

Many diagnostic devices are suitable for mounting on our Advanced Mobile Computer Carts.



Item 5AL/CLAMP

Clamp screw for needle container holder in combination with an accessory rail.

The clamp screw tightens onto the accessory rail. The stainless steel needle container holder can then be placed and fitted in the desired position.

The accessory rail and needle container holder must be ordered separately.

Below is an overview of the available needle container holders in a fixed size.

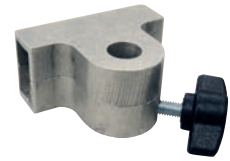

Description	Size in mm	Item nos. Needle container holders	Shape
Semi-circular	130 x 130 mm	5AL/SBH	
Square	200 x 200 mm	5AL/SBH/200	
Small square	150 x 150 mm	5AL/SBH/150	
Rectangular	100 x 180 mm	5AL/SBH/100	
Oval	240 x 160 mm	5AL/SBH/240	

Item 5AL/IV

Infusion stand

Chrome-plated steel

Infusion stand, height-adjustable with plastic quick coupler.

This is usually mounted on the Mobile Computer Cart's column.



Various holders for diagnostic equipment

Special holders for diagnostic equipment from various brands, including Hillrom, Mindray, Phillips and GE.





Item 5AL/3/TILT
Holder with 3-compartment tilt bin and mounting bracket
301 x 140 x 150 mm (WxDxH)
White polystyrene holder with transparent tilt bins
The tilt bin can be separated into three compartments with dividers. The tilt bin holder will be mounted with a special mounting bracket.



Item 5AL/PRT/TRAY
Printer tray
Simple Trespa tray, e.g. for printer placement. Suitable for storing or transporting many types of equipment.



Bottom tray for the Mobile Computer Cart
Solidly designed, stable tray, e.g. for printer placement. Suitable for storing or transporting many types of equipment.

Item trays	Size in mm (WxD)
5AL/B/TRAY	450 x 330 mm
5AL/B/TRAY/500	500 x 300 mm



Item 5AL/WF
Fold-out extra Worktop

The fold-out worktop is manually operated. A Trespa 30x40 shelf that can serve as additional workspace is permanently mounted on the mechanism.



Item 5AL/HO/PH/C
Holder for pharmacist containers

Inside this holder various logistical containers can be placed. Like nesting and folding containers made by RAKO, BITO, UTZ etc.

The holder will be mounted on the Mobile Computer Cart.

More to know Tilt bins

Cleaning

Parts can be manually cleaned with neutral disinfectants. Products containing alcohol should not be used on the holders with tilt bins.

Temperature tolerance

Max. 50° C

Applications

The tilt bins are especially suitable for storing small items. Retrieving items from the bins is easy, thanks to the large grab opening created when the bins are tilted open.

The bins can also be used in a storage area or for the technical service, for example. They can be mounted directly on walls and cabinets.

Holder mounting

The tilt bin holders are mounted onto the Mobile Computer Cart by our technicians.

Variations

A 600 mm-wide tilt bin holder is available for use with multiple tilt bins.

Accessories

Standard Drawer System

All to know Drawer systems

Drawer dividers

Dividers are available for each drawer system.

Drawer locking system

Each drawer system has its own locking options.

Medication drawers

The Mobile Computer Cart below has been outfitted with a modular medication cassette with twelve 120 mm wide medication drawers. A Zebra printer and a Datalogic scanner complete the medication dispensing system.



Plastic drawer system for Mobile Computer Carts

Budget drawer system.

The standard external dimensions of the drawer unit are 426 x 108 x 415 mm (WxHxD). The standard internal dimensions of a drawer are 399 x 70 x 298 mm (WxHxD).

For example, various measuring equipment can be stored in a storage drawer, such as blood pressure monitor, temperature meter, PDA accessories or smart glasses. Hip airbag accessories also fit well in the drawer systems.

Routinely equipped with a key lock.



Lades	External dimensions W x H x D in mm	Internal dimensions W x H x D in mm
Single plastic drawer Item 5AL/DR	426 x 108 x 415 mm	399 x 70 x 298 mm
Double-high plastic drawer Item 5AL/DR/L	430 x 216 x 407 mm	345 x 180 x 290 mm
Plastic drawer unit with 4 medication bins Item 5AL/DR/4	External dimensions drawer unit 426 x 108 x 415 mm	Internal dimensions drawer 85 x 75 x 296 mm

Item 5AL/DR/S/L

Steel drawer system for the Mobile Computer Carts
Steel drawer system with a luxury appearance.

The standard external dimensions of the drawer unit are 392 x 405 x 346 mm (WxHxD). The standard internal dimensions of a drawer are 319 x 87 x 300 mm (WxHxD).

Routinely equipped with a key lock.



Aluminum Drawer System



Aluminum drawer system
White, epoxy-coated enclosure.

Robust, aluminum drawer system.

A drawer unit has the possibility for multiple layers of drawers, with optional separations and a key or a PIN code lock for each layer.

There is also a raised edge available on top of the drawer unit, e.g. for placement of a medication tray.



Standard external and internal dimensions:

Drawers	External dimensions WxHxD in mm	Internal dimensions WxHxD in mm
Large Item 5AL/DR/AL/L	500 x 150 x 330 mm	450 x 110 x 300 mm
Medium large Item 5AL/DR/AL/ML	450 x 180 x 330 mm Suitable for blood collection tubes etc.	400 x 140 x 300 mm
Medium Item 5AL/DR/AL/M	450 x 150 x 330 mm	400 x 110 x 300 mm
Small Item 5AL/DR/AL/S	450 x 110 x 330 mm	400 x 70 x 300 mm



Customisation is possible for orders of 25 units or more.

Item of the raised edges for the three different sizes of the drawer units:

Large: **5AL/DR/AL/RE/L**
Medium: **5AL/DR/AL/RE/M**
Small: **5AL/DR/AL/RE/S**

Item of the dividers for the three different sizes of the drawer units:
Large: **5AL/DR/AL/L/DIV**
Medium: **5AL/DR/AL/M/DIV**
Small: **5AL/DR/AL/S/DIV**



A heavy-duty column is required when adding a drawer system or medication cassette.

Item 5AL/COW/HDC

Ready to Roll deliveries are available.

Accessories

HTM71 Modular Module Holders

All to know Modular module holders

ISO3394 modules

All our modules fit in the drawers of the modular module holders.

For every module there are dividers available.

Module holder 600 x 400 mm

There is also a 600x400 mm modular module holder available.

(Item 5AL/MD/600).

A lock operated by either PIN code or a Mifare employee ID card, with optional track & trace function, can be mounted on this module holder.



Item 5AL/MD/300

Module holder for Mobile Computer Carts
[300 x 400 mm](#) with a height of 200 mm

This innovative module holder for Mobile Computer Carts is suitable for 1/2 or semi-modular modules within the ISO 3394 system.

The steel enclosure and telescopic drawers feature the same quality as our popular loading carts. The holder has a key lock. Each drawer has its own plastic handle. These are available in three colours: light gray, dark blue and red.

Multiple drawer arrangements are possible within the fixed height of 200 mm.

The most popular drawer arrangement is:

- 2 x 100 mm high

Also available is a module holder with a height of 300 mm (Item 5AL/MD/300/3).

The most popular drawer arrangements of the 300 mm high module holder are:

- 3 x 100 mm high
- or:
- 1 x 100 mm high
- 1 x 200 mm high





Modular medication cassettes

This innovative, portable, modular medication cassette is designed in modular sizes – 600 x 400 mm. The cassettes slide effortlessly into every computer cart, rack or cabinet built for the ISO 3394 system.

A wide range of locks are available: key, Mifare or other electronic (code) locks. See the next page for an overview of available electronic pincode locks.

A wide range of accessories is available: medication drawer dividers and separators; cover plates for the information box; etc.

The medication cassettes are available in white plastic. They have between one and five layers, with 4 to 30 medication drawers, respectively. Medication drawers are available in 80 mm and 120 mm wide.

There is also an option to get medication drawers in odd sizes, see below for an overview.

Aluminium drawers for the medication cassette

Specially designed aluminium drawers for use in the modular medication cassette. If needed the drawers can be provided with dividers. Please take into account that there is a longer delivery time for these special aluminum drawers and the separations.



Special aluminium drawers	External dimensions W x H x D in mm	Dividers
Item 5AL/SP/AL/DR/FW Drawer for entire width	480 x 80 x 338 mm	Item 5AL/SP/AL/DIV/FW
Item 5AL/SP/AL/DR/HW Half-width drawer	240 x 80 x 338 mm	Item 5AL/SP/AL/DIV/HW
Item 5AL/SP/AL/DR/DH/HW Double-high half-width drawer	240 x 160 x 338 mm	Item 5AL/SP/AL/DIV/DH/HW

More to know

Modular medication cassette holders for Mobile Computer Carts

Item 5AL/HD/MC/R
Holder for removable medication cassette.

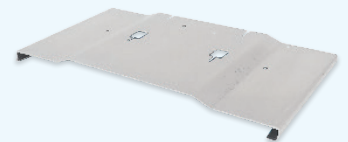

Item 5AL/HD/MC/F
Medication cassette holder for permanent mounting of the medication cassette to the mobile cart.

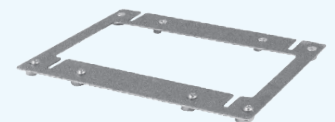

Medication Mobile Computer Cart with IT

MedEye Application





Single Sign-on

**Single-sign-on possibilities via active directory.
For use with Windows, Imprivata and Evidian.**

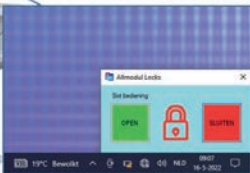

Optimising and making the workflow more efficient through the single sign-on options. This makes the medication dispensing process safer.

All to know

IP67 Peripherals



Item 5AL/KB Medical keyboard QWERTY

- IP67 medical keyboard
- ✓ Water-resistant, dust-free and anti-bacterial.
- ✓ Suitable for all common disinfectants.
- ✓ Switch keyboard on and off for cleaning.
- ✓ Easy to clean due to smooth surface.
- ✓ Includes 1 antibacterial silicone cover.

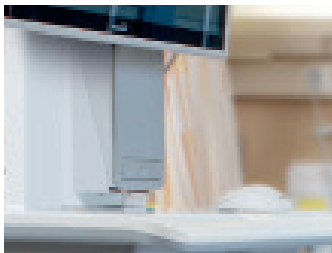

Item 5AL/MED/E MedEye holder

The holder is mounted onto the monitor column (or accessory stand). This makes MedEye always within easy reach.



Item 5AL/E/CL Simple electronic PIN code lock

The CompX Regulator is an Electronic Push Button Lock.

Can be cleaned manually with PH neutral cleaning agents.



Item 5AL/EPB/A/WH Electronic (RFID) & PIN code lock

The Electronic RFID lock is Mifare capable and supplied pre-programmed to your requirements.

The lock can be cleaned, manually, with PH neutral cleaning agents.



Item 5AL/MO IP67 medical mouse

- ✓ Water-resistant, dust-free and anti-bacterial.
- ✓ Suitable for all common disinfectants.
- ✓ Scroll wheel.

Mobile Computer Cart with IT *Powered Cart*





- 1** Medical monitors for the Powered Mobile Computer Cart
- The Powered Mobile Computer Cart shown in the adjacent image has a Planar AIO PC.
- We can also supply other medical AIO PCs or monitors.

All to know

IP68 Peripherals



Item 5AL/KB/IP68
Medical keyboard QWERTY

- IP68 medical keyboard
- ✓ Waterproof, dust-free, immersion-proof and anti-bacterial.
 - ✓ Suitable for all common disinfectants.
 - ✓ Switch keyboard on and off for cleaning.
 - ✓ Nano silver antibacterial coating. Closed housing prevents contamination.



- 2** Keyboards and mice, including by All Modul, Medigenic, Purekeys and Man&Machine
- We supply various brands of medical keyboards and mice, including Medigenic or a Purekeys keyboard with integrated touchpad.



- 3** **Item 5AL/MI/RFID/CR**
Mifare RFID card reader
- A Mifare RFID card reader can be mounted underneath the Worktop. A sticker can be placed on top of the Worktop to alert users to the reader's presence.



- 4** **Item 5AL/PRT/TRAY**
Printer tray
- Simple Trespa tray, e.g. for printer placement. Suitable for storing or transporting many types of equipment.



- Item 5AL/MO/IP68**
IP68 medical mouse
- ✓ Waterproof, immersion-proof, dust-free and anti-bacterial.
 - ✓ Suitable for all common disinfectants.



- Zebra (label) printers
- Zebra printers for wristbands or other labeling.
- See our website: bristolmaid.com

Accessories / Options

All to know

IP68 Peripherals



Item 5AL/KB/IP68

Medical keyboard QWERTY

IP68 medical keyboard

- ✓ Waterproof, dust-free, immersion-proof and anti-bacterial.
- ✓ Suitable for all common disinfectants.
- ✓ Switch keyboard on and off for cleaning.
- ✓ Nano silver antibacterial coating. Closed housing prevents contamination.



Item 5AL/MO/IP68

IP68 medical mouse

- ✓ Waterproof, immersion-proof, dust-free and anti-bacterial.
- ✓ Suitable for all common disinfectants.

Item 5AL/LPC

Laptop Clamp

For securing laptop



Item 5AL/KT

Keyboard Tray

Pull out keyboard tray

Tilt adjustable & features an integrated wrist support

Retractable mouse tray, configurable for right / left hand

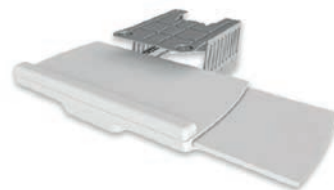

Item 5AL/KB

QWERTY Keyboard

Water-resistant, dust free & antibacterial (IP67)

Suitable for use with all common disinfectants

Can be turned off for cleaning

Antibacterial silicone cover



Item 5AL/BMO

Double barcode scanner holder behind the display

Scroll wheel

Water-resistant, dust free & antibacterial

Suitable for use with all common disinfectants





Item 5AL/PA
Power Adaptor

Adaptor to allow connectivity to the hardware



Item 5AL/RPC
Retractable Power Cable
Coiled Cable
Fitted with a UK 3-pin plug



Item 5AL/DR
Drawer Unit
Single drawer
Supplied with two keys
Up to two drawers can be fitted to a cart

All to know Drawer systems

Drawer dividers

Dividers are available for each drawer system.

Drawer locking system

Each drawer system has its own locking options.

Medication drawers

The Mobile Computer Cart below has been outfitted with a modular medication cassette with twelve 120 mm wide medication drawers. A Zebra printer and a Datalogic scanner complete the medication dispensing system.



AIO PC, 3 Battery Cells, I5, Touch 8GB, 256 GB

With Internal Battery Cells

The 24" AIO PC, 3 Battery Cells, I5, Touch comes with 8GB of RAM and 256GB of storage. The computer has a full HD front camera, a built-in LED reading light and HDMI video out supporting up to 4K UHD resolution.

The AIO PC has 24" capacitive touchscreen for ease of use in a medical environment.



Features 24" AIO PC, 3 Battery Cells, I5, Touch

- ✓ Three integrated hot-swappable batteries
- ✓ High resolution 24" capacitive touchscreen
- ✓ I5 Pentium processor
- ✓ Fanless, IP65-rated front panel, IPX2-rated enclosure
- ✓ Built-in LED reading light
- ✓ HDMI video-out, support up to 4k UHD resolution
- ✓ VESA compatibility to maximise installation flexibility (100 x 100mm)
- ✓ 8GB Ram
- ✓ 256GB Storage
- ✓ Microsoft Windows 10
- ✓ Display resolution 1920 x 1080
- ✓ WLAN, Bluetooth
- ✓ 2 USB 2.0 ports, 1 COM port, 1 x HDMI-out, DC-in & DC-out
- ✓ AC/DC adaptor
- ✓ Full-HD front camera, RFID-reader, smart card reader
- ✓ 6.4kg without batteries, 7.9kg including batteries
- ✓ Energy Efficient

24" Terra Monitor

With Internal Battery Cells

The Terra Monitor includes a 24" screen and built in speakers.
With built-in LED backlight, headphone out socket HDMI DisplayPort 1.2.
The monitor has an anti-reflective screen and features 1920 x 1080 full HD resolution
for a clear and detailed picture.

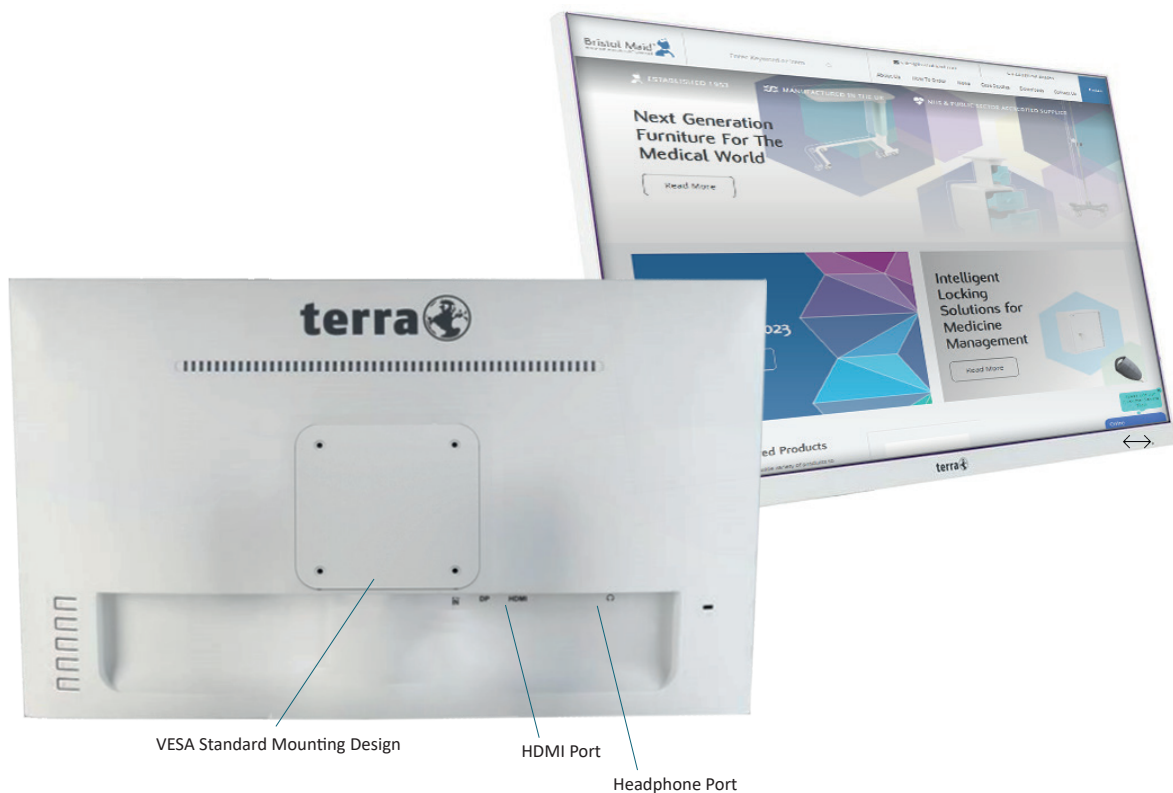

Features 24" Terra Monitor

- ✓ Multiple video outputs – HDMI x 2 and DisplayPort x 1
- ✓ 24" IPS panel technology screen
- ✓ 1920 x 1080 Full HD
- ✓ Anti-reflective
- ✓ LED backlight
- ✓ Headphone out
- ✓ Lightweight 3kg for easy mounting
- ✓ HDMI DisplayPort 1.2
- ✓ HDCP
- ✓ Built in speakers
- ✓ 100 x 100mm VESA mount
- ✓ 12v
- ✓ Energy rating D 14Wh/1000h
- ✓ Energy Efficient

Caretray Trolley - Laptop

Item CTLAPTM1/10/3S2D/HSB

Applications

- √ Suitable for use with Electronic Prescribing & Medicines Administration (EPMA) & Electronic Patient Records (EPR)

Convenience

- √ Two locking options
- √ High Security Bolt Lock supplied with two keys
- √ Electronic Push Button Lock - Programmable four-digit code
- √ Trolley pre-configured with Laptop Holder, Removable, Swing Arm
- √ Trays feature an integral handle with a plastic clip-on label cover (coloured label strips supplied white, blue, green, yellow & red)
- √ Each tray supplied with 2 x long & 2 x short dividers
- √ Max load per tray 5kg
- √ Polyurethane ring buffers offer protection to both the trolley & fabric of the building
- √ 100mm polymer castors, 2 off braking
- √ When not in use, trolleys storing medicines should be secured to the wall using a Security



Hygienic

- √ Smooth surface
- √ Radiused edges assists cleaning
- √ Quick & easy
- √ Disassembly, assists thorough & deep cleaning
- √ Compatible with steam cleaning
- √ Integral rim at the front contains spillages

Services

- √ Delivered fully assembled & ready to use
- √ Comprehensive warranty & service options

Quality

- √ Robust construction
- √ Anti-static castors
- √ Fully welded mild steel frame
- √ Solid grade laminate door & back panel providing security for the contents of the trays

Ergonomics

- √ Lightweight construction to assist easy manoeuvrability
- √ Easy height adjustment laptop arm
- √ Swing arm aids positioning of laptop
- √ No sharp edges

Overview of product specifications		
Total load capacity	Max load per tray 5kg, Integral rim max load 30kg	
Plastic top dimensions	455 x 455 (internal) at height 968mm	
Laptop fixation		
Laptop support	Display type	Laptop/notebook
	Maximum laptop width	455 / up to 17" laptops

Description	High Security Bolt Lock	Electronic Push Button Lock	Weight
3 x 100mm, 2 x 150mm Trays	CTLAPTM1/10/3S2D/HSB	CTLAPTM1/10/3S2D/EPB	39.3kg
4 x 100mm, 1 x 150mm Trays	CTLAPTM1/10/4S1D/HSB	CTLAPTM1/10/4S1D/EPB	39.0kg
6 x 100mm Trays	CTLAPTM1/10/6S/HSB	CTLAPTM1/10/6S/EPB	40.1kg

Options / Accessories

- CT/WF - Work Flap
- CT/DEFIB - Adjustable Defibrillator Platform
- CT/AIR - Airway Tube Holder
- CT/ALC - Alcohol Gel Holder
- CT/CYD - Cylinder Holder
- MT/1/6F - Security Clamp

Dimensions



Technical Information



Dimensions & Weight

Dimensions are stated in millimetres (width x depth x height)

Weights are stated in kilograms

Please ensure you are aware of the item size & weight prior to ordering

Dimensions are always from the largest point

Medical Devices

Where applicable, Hospital Metalcraft product is marked with the CE symbol to demonstrate compliance with the essential requirements of any European Directives (& transposing regulations) that may apply & for which a Declaration of Conformity is held. Hospital Metalcraft is registered with the MHRA (Medicines & Healthcare Regulatory Authority) in connection with product classified as 'Class 1 Medical Devices' for purposes of the Medical Devices Directive (93/42/EEC) with the registration number CA001358.

WEEE Regulations

Hospital Metalcraft meets its obligations as a business-to-business producer of Electrical and Electronic Equipment (EEE) through:

Membership of the Veolia Environmental Services WEEE, (Waste Electrical & Electronic

Equipment), Producer Compliance Scheme (Registration No. WEE/KE0677RX)

Marking EEE placed on the market by Hospital Metalcraft with the mandatory crossed out wheeled bin symbol & Bristol Maid™ logo

Making information available (for EEE placed on the market after April 2007), to assist those engaged in treatment, recovery & recycling activities

Arranging for the collection, treatment, recovery & environmentally sound disposal of obligated

Preventative Maintenance & Service Support

Bristol Maid™ products are designed & manufactured to cater for the demands of the healthcare environment, with the majority (under normal conditions) providing many years of trouble-free service. Where annual maintenance or periodic inspections are required, we can offer comprehensive planned preventative maintenance through either a scheduled service contract or call out by our own trained Engineers. For your peace of mind & continued product reliability, please contact our customer service team for details on the following services.

- Preventative maintenance contracts & packages
- Supply of spare parts
- Site audit & equipment recommendations

Area Sales Representatives



Steve Poller
07711 095899
spoller@bristolmaid.com



Republic of Ireland & Export
Dave Morton-Jones
+44 (0)1258 484468
export@bristolmaid.com



North
Samantha Lowe
07790 916052
nwest@bristolmaid.com



Midlands
Ian Newbould
07500 039301
midlands@bristolmaid.com



London
Chris Davis
07725 543862
london@bristolmaid.com



South & South West
Jason Dutfield
07876 441477
sswest@bristolmaid.com

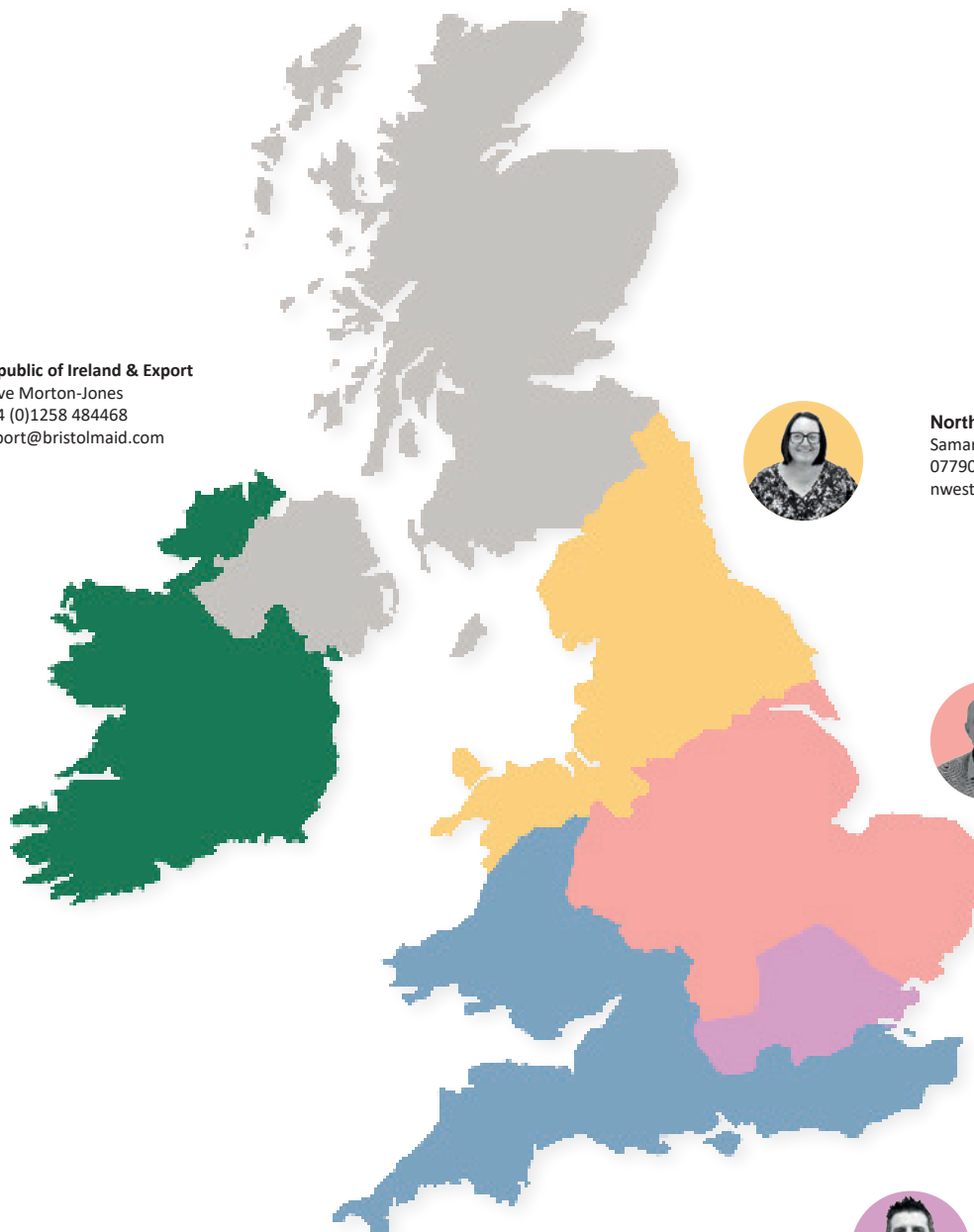

Mobile Computer Carts

Complete product range

This brochure provides an overview of the Mobile Computer Carts we can supply. Customisation is possible, please contact us to discuss your requirements.

